



SAFETY AT THE HIGHEST LEVEL

KEE WALK Step Over Operation & Maintenance Manual



CONTENTS	PAGE
System Overview	1
Checking the Step Over System's Components	3
Platforms for the Major Roof Types	6
Assembling the Step Over	8
Finished Step Over	13
Kee Walk Mini Step Over	14
Assembling and fixing the Mini Step Over - Fixed Version	15
Assembling and fixing the Mini Step Over - Free standingg	16
Kee Walk Step Over System Recertification	17

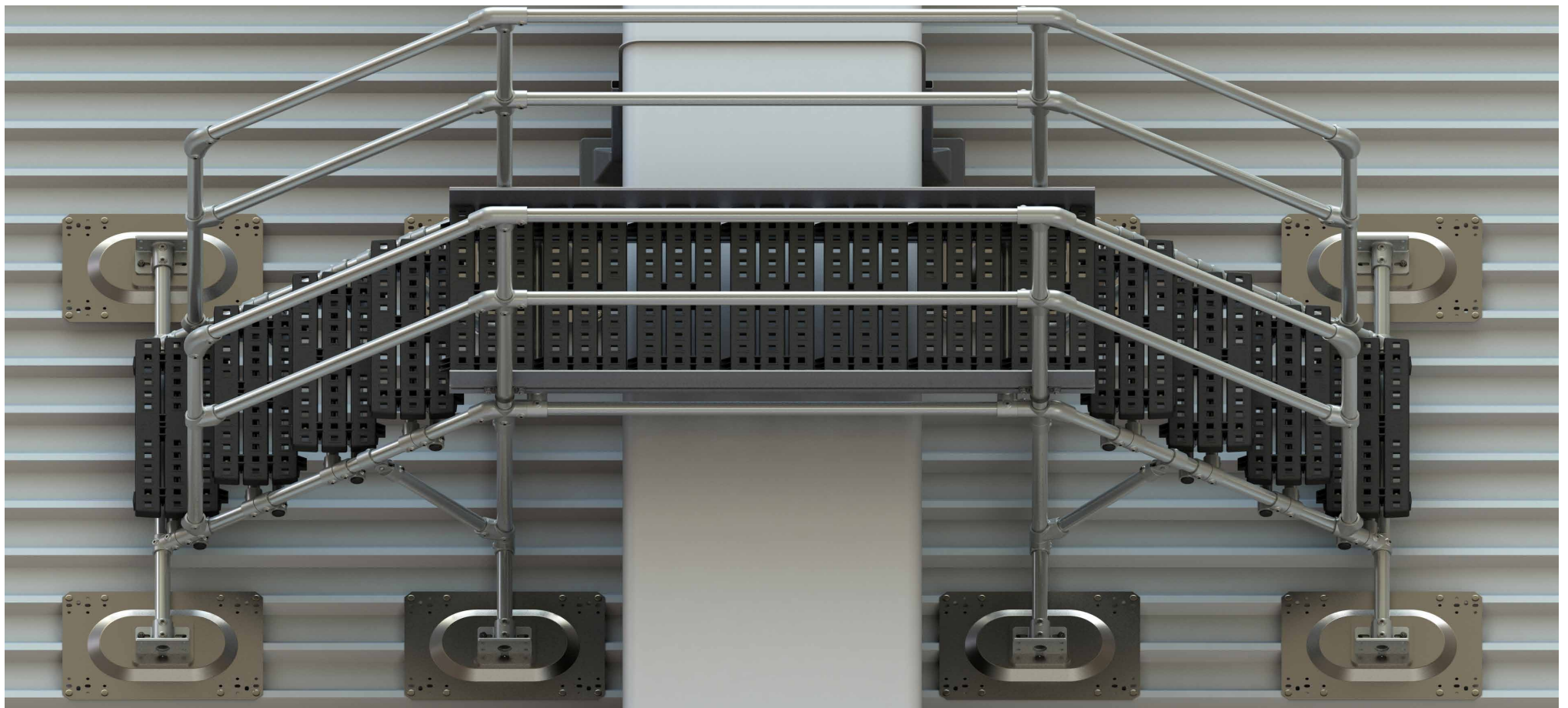



Step Over

KEE WALK® Step Over is a complete range of safety Step Overs designed specifically to provide permanent safe access for areas on roofs or in warehouses where regular access for maintenance and inspection is required.

A KEE WALK® Step Over system is designed to provide a safe means of access up and over obstructions present in a designated walkway as part of a safe roof access system or as a standalone item used internally (i.e. warehousing) when access is required. Can be combined with KEE WALK, or as a stand alone item when access or egress is required over an obstruction.

The Step Over system provides both a demarcation route for flat roofs which are not accessible to the public, where access is still required for the purpose of carrying out repairs and maintenance. They can also be used within a warehousing environment or internal application where access up and over plant or equipment is required in order to provide safe passage from point to point.



APPLICATION

KEE WALK® Step Over has been designed to be fully adjustable and can accommodate heights from 600mm up to 1400mm.

DURABILITY

KEE WALK® Step Over is available in a range of high quality finishes. The components are supplied with a galvanised finish carried out to BS EN ISO 1461 and ASTM A53: Hot Dip Galvanised Coatings Specification and Testing Methods, giving an average coating of between 65-85 microns. All cast clamps have Threadcoat applied to all tapped holes. All grub screws are carbon steel and have Kee Coat protection applied to ensure minimal maintenance.



COMPONENT BASED SYSTEMS

All products consist of high quality tubing that seamlessly complements our existing safety portfolio. KEE WALK® Step Over mounts easily to all variants of the KEE WALK Walkway & KEEGUARD systems as well as Safe Access Solutions such as Mobile Access Platforms & Static Access Platforms.

VERSATILE SYSTEMS

The KEE WALK® Step Over range has been specially designed with different heights and foot styles to accommodate all levels and roof types. The flexibility of the KEE KLAMP design allows the systems to be used on plant congested or complex detailed roofs. The product range has been extended to suit specific requirements and includes the standard design and bespoke solutions.



TESTING & CERTIFICATION

Tested in accordance with the following
(See Specification Section for full details) :-
EN ISO 14122: 2016 Part 3

KEE WALK® Step Over systems do not require physical fixing to the building's structure. The complete system's design, manufacture, testing and installation have been internally assessed and designed in accordance with EN 14122-3 European Standards.

OFFICIAL DOCUMENTATION

All Systems comply with the following: - Work at Height Regulations.
- HSG-33, Health & Safety in Roof work
- HSE INDG 284- Working on Flat Roofs
- BS EN 516: 2006

AESTHETICS

The smooth lines of the standard galvanised finish can be further enhanced by the application of powder coating to EN 13438.

MATERIALS

Steel tubing to EN 10255. 42.4mm diameter tube x 3.2mm wall thickness. All steel components galvanised to BS EN ISO 1461. All fixings are hot dipped galvanised to BS EN ISO 1461. All cast clamps have Threadcoat applied to all tapped holes. All grub screws are carbon steel and have Kee Coat protection applied to ensure minimal maintenance. Where tubing is cut on site zinc rich paint is applied to the cut end of the tube.

Powder Coating to EN 13438.

KEE WALK tread is manufactured in high grade nylon/aluminium incorporating raised textured sections. Open tread design ensures water drains away

SYSTEMS DISTRIBUTORS

KEE WALK® Step Over is available as a supply and installation service or component supply only. Products are available from Kee Safety directly or one of its licensed distributors.

Checking the Step Over System's Components

3. Designation and function of the components for standard systems

The Step Over system consists of the following pre-assembled modules & individual components. The exact number of individual components depends upon the length and construction of a specific system. All fittings are cast from malleable cast iron to BS EN 1562 and galvanised to BS EN ISO 1461 and full part numbers for reference are detailed below. Aluminium toe board is 6062-T6 grade.

Note: A complete list of all parts and details on the total weight of the Step Over system is provided with the delivery. The load-bearing capacity of the roof must be equal to or exceed the capacity specified.

 <p>10-7</p>	 <p>10-76</p>	 <p>29-7</p>	 <p>55-7</p>	 <p>C50-77</p>
 <p>325-7</p>	 <p>326-7</p>	 <p>45-7</p>	 <p>74-7</p>	 <p>199-6</p>
 <p>62-7</p>	 <p>63-7</p>	 <p>69-7</p>	 <p>77-7</p>	 <p>105-7</p>
 <p>440-7</p>	 <p>KGTF1</p>	 <p>TB3-7</p>	 <p>TB150</p>	 <p>TRSTEPASSY</p>

Checking the Step Over System's Components

A



Weighted foot assembly

B



Front guardrail upright

C



Step module guardrails

D



Bridge module guardrails

E



Toe board assembly

H



Stair tread assembly

F



Bridge module

G



Back upright assembly

Checking the Step Over System's Components

Exploded view of system layout and location of components and sub-assemblies:

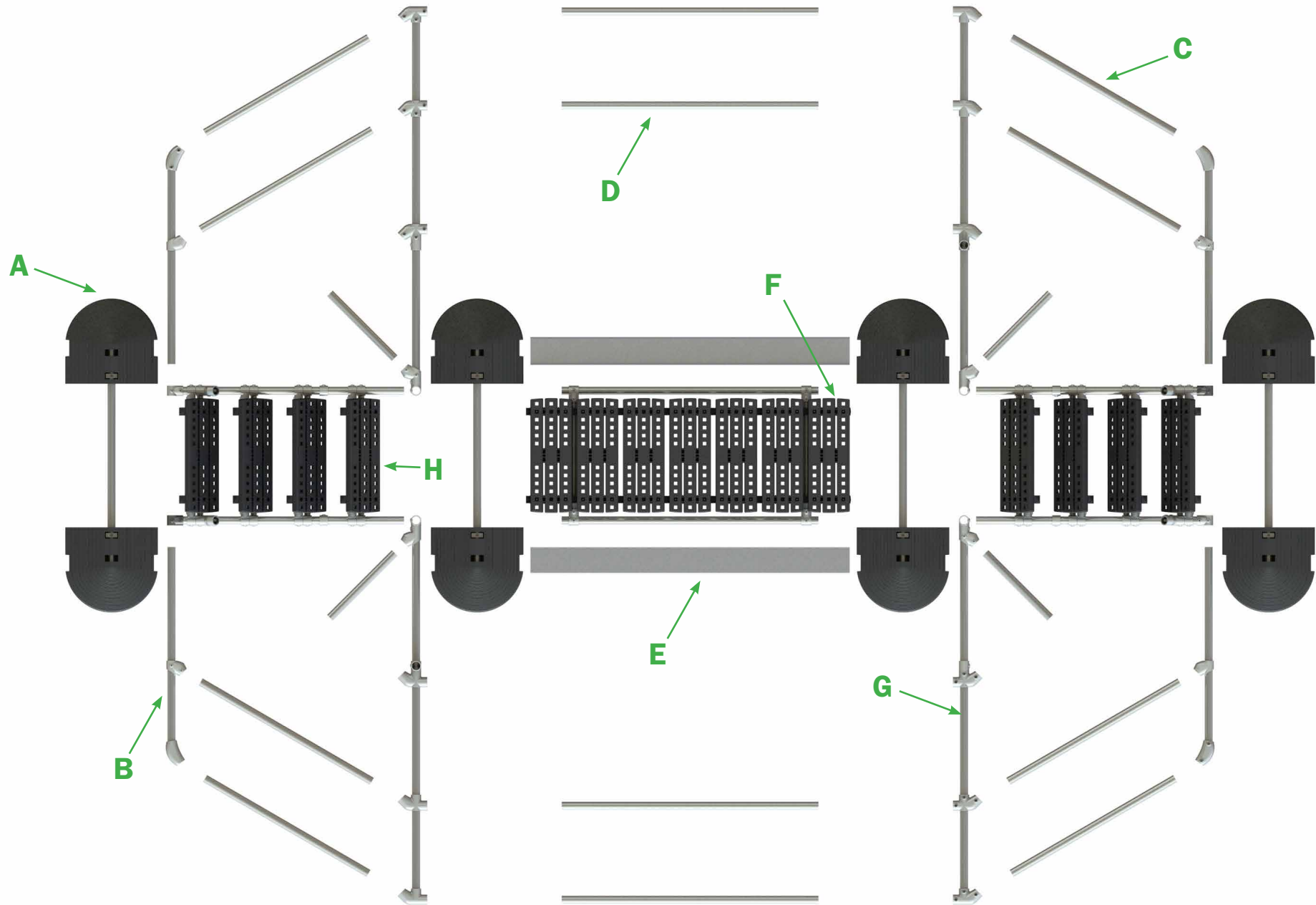

Platforms for the Major Roof Types

4. The Kee Safety Step Over modules are available to suit all major roof types

The Step Over range consists of a number of different configurations to suit the major flat roof types. Membrane and concrete roof type platforms are standard units, whereas metal profile roofs are bespoke to the particular application, requiring a survey and semi-bespoke base plate layout design. This will ensure a perfect fit and other height/width/length variables can be accommodated as a bespoke solution - contact Kee Safety for further information.

Step Overs for Membrane/Asphalt/PVC roofs



Step Over shown with 440 base feet for Membrane/Asphalt/PVC roofs.

Roof Type	Obstacle Height (mm)	Obstacle Width (mm)	Foot Type	Part Number
Membrane/Asphalt/PVC	600	1000	440-7	STMB600
Membrane/Asphalt/PVC	800	1000	440-7	STMB800
Membrane/Asphalt/PVC	1000	1000	440-7	STMB1000
Membrane/Asphalt/PVC	1200	1000	440-7	STMB1200
Membrane/Asphalt/PVC	1400	1000	440-7	STMB1400

Platforms for the Major Roof Types

The Kee Safety Step Over modules are available to suit all major roof types

The Step Over range consists of a number of different configurations to suit the major flat roof types. Membrane and concrete roof type platforms are standard units whereas metal profile roofs are bespoke to the particular application, requiring a survey and semi-bespoke base plate layout design. This will ensure a perfect fit and other height/width/length variables can be accommodated as a bespoke solution - contact Kee Safety for further information. Where access is limited on a roof, or within a warehouse environment, we can offer the below solution.

Concrete floors/restricted access roofs*

















Roof Type	Obstacle Height (mm)	Obstacle Width (mm)	Foot Type	Part Number
Concrete	600	1000	62-7/63-7	STCR600
Concrete	800	1000	62-7/63-7	STCR800
Concrete	1000	1000	62-7/63-7	STCR1000
Concrete	1200	1000	62-7/63-7	STCR1200
Concrete	1400	1000	62-7/63-7	STCR1400

*Concrete slab and elastomeric pad to be used on membrane/asphalt/PVC roofs to spread the imposed load from the platform.

5. Installation should only be carried out once the design has been verified in the Step Over Configurator and the installer has been fully trained by Kee Safety.

Tool list:

-  Ratchet
-  Hex key socket screw sized 5/16"AF
-  Torque wrench 10-60Nm
-  Electric/battery drill
-  Electric/battery impact driver
-  Selection of drill bits – including 8.5mm diameter bit
-  Tape measure
-  Line and level
-  Full metric socket set
-  Fell set metric spanners
-  Full set of metric Allen keys
-  Full set of imperial Allen keys
-  Copper/rubber mallet
-  Rags and cleaning fluid

STEP 1

Assembling back leg upright with weights and cross rail

Take both back upright assemblies (Part G) to the position of the obstacle, along with the weighted foot assemblies (Part A).

Starting with the left-hand side back upright assembly, up end the upright such that it is orientated with the 10-7 fitting at the bottom. Pick up the weight cross rail, and feed through into the lower fitting of the upright, and slide the right-hand side towards the left.

Insert the cross rail at mid-point to connect both uprights together.

Insert the 74-7 fittings into the 440-7 weights and add the weights to either end of the tube, ensuring the weights are inserted fully. Tighten the 74-7 grub screws to 39Nm.

Manoeuvre the assembled rear upright into position at the point of install.

Tighten all grub screws to the required 39Nm torque setting.



Assembling the Step Over

STEP 2 - Repeat Step 1 for other side of stair case

Repeating of Step 1 enables the other side of the uprights to be built, which in turn allows the next phase of the build to commence.

Repeating all sub sets of step 1 to build other side of platform uprights



STEP 3 - Assemble bridge module and guardrail onto rear leg uprights

Take the bridge platform subassembly (Part F) framework and insert into the 326 fitting present on one side of the rear uprights, followed by the guardrails (Part B) into the fittings further up the upright.

Bring the opposite outer leg assembly to meet the platform, and locate tubes from bridge module subframe into the slope fittings present on the uprights.

Add the Kee Walk bridge tread assembly to the substrate, ensuring it is centred left/right and front/back and fix into place using the 105-7 fittings to the underside and securing in place with self-drilling screw.

Inserting bridge subframe tubes into uprights at obstruction

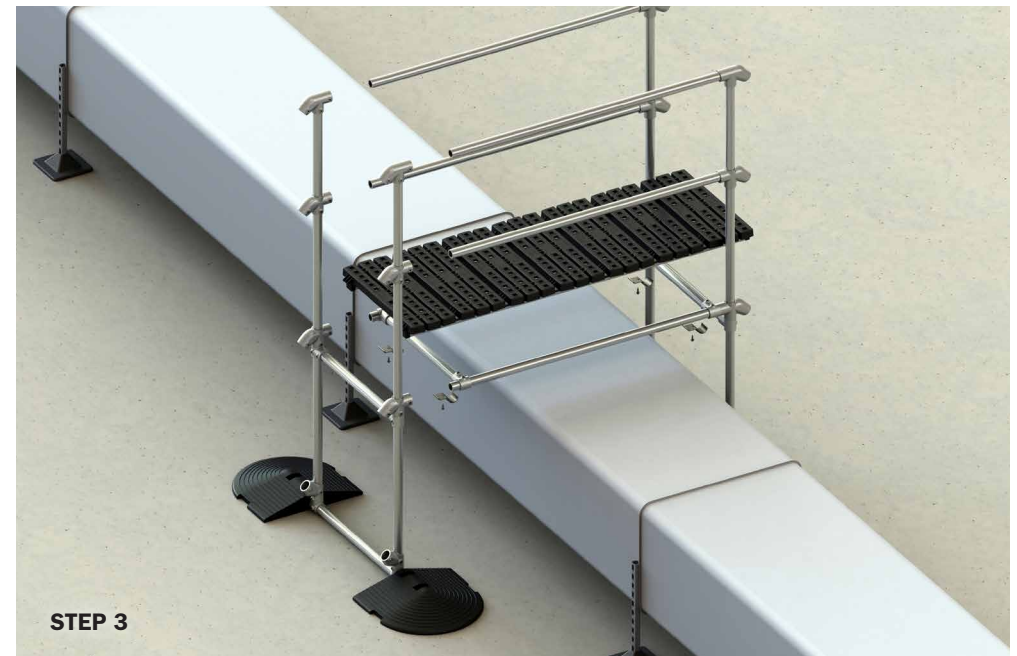

Inserting bridge subframe tubes into uprights at obstruction and securing walkway

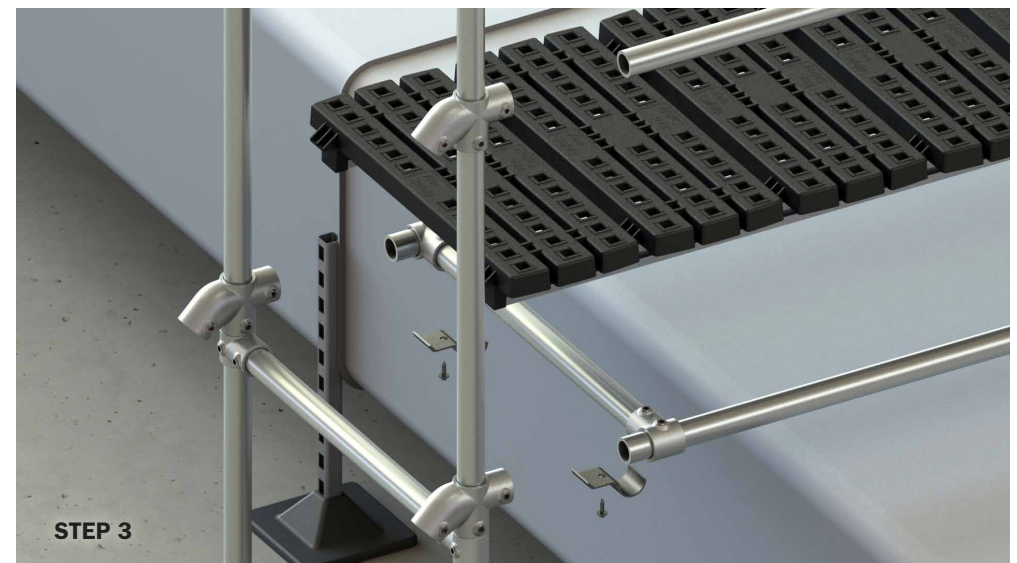

Assembling the Step Over

STEP 4 - Staircase assembly

Take the stair tread assembly module (Part H) to the area in which it is to be installed, and collect the 440 weights, cross tubes and relevant fittings (Part A).

Insert the lower weight cross tube into the lower 10-7 fittings sliding from left to right; space the tube such that an equal overhang exists both sides and tighten grub screws on 10-7's to 39Nm.

Locate cross brace tube into C50-77 fitting and tighten.

Take the pre-assembled stair module and move towards assembled bridge platform in previous steps.

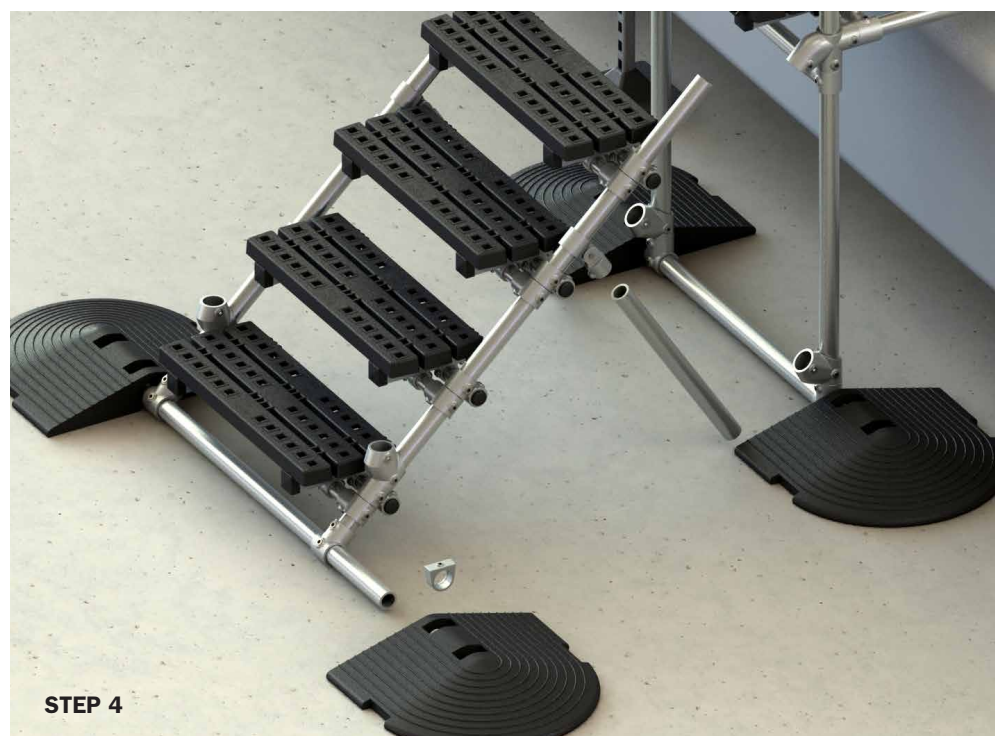

STEP 5 - Staircase assembly

Locate upper tube from staircase and brace tube in the correct orientation to meet the corresponding tube sockets in the lower 29-7 and upper 326-7 fitting.

Starting with the upper tube, manoeuvre the lower tube down towards the stair assembly and lower the staircase so that the upper tube can be inserted into the 326-7 fitting. Before fitting fully, locate the lower tube into 29-7 fitting.

Push both tubes on both sides home, ensuring staircase is square. Lightly tighten grub screws to locate stair assembly into place.

Insert the 74-7 fitting into the weights and slide the weights onto the end of the tube ensuring that they are fully inserted.

Double check for location, once happy tighten all grub screws to 39Nm. Repeat the procedure for the other staircase.

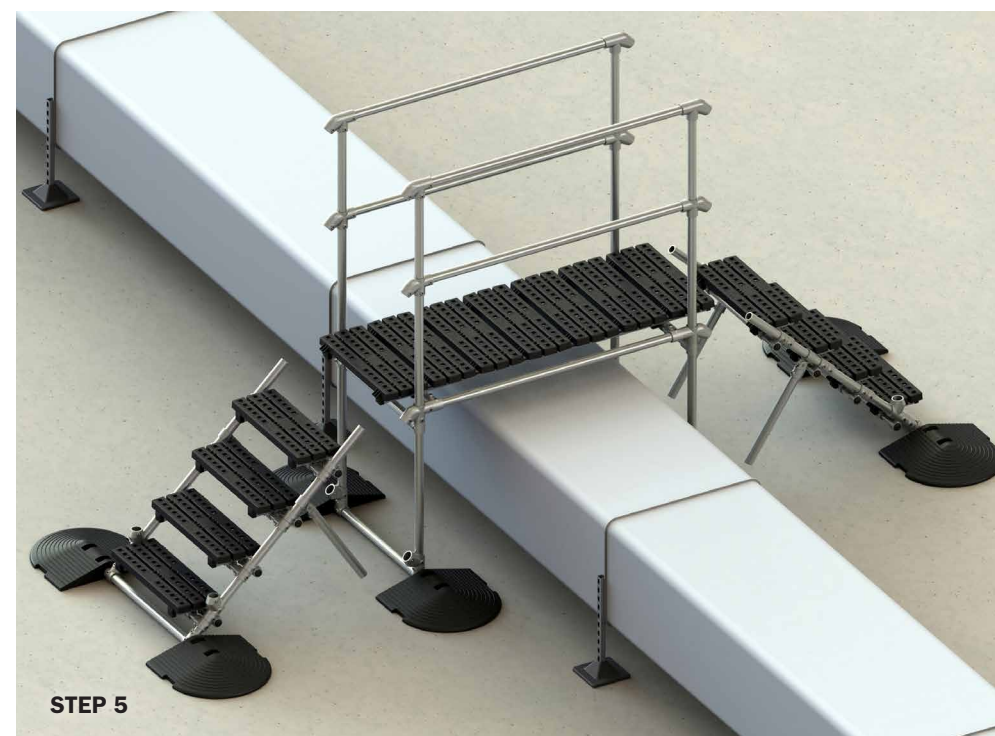

Assembling the Step Over

STEP 6 - Assemble the remaining guardrails and toe board

Take the forward assembled uprights (Part B) and insert into the 29-7 fitting present on the stair assembly and loosely tighten the fittings.

Starting on one side, insert the two inclined hand rails (Part C) into the 326-7 fittings present on the rear upright, and manoeuvring the front upright forward insert both rails in the 29-7 and the 55-7 fittings, move the upright back to its upright position and loosely tighten.

Using a spirit level, ensure the forward upright is plumb and level in the X and Y plane, once level, tighten all grub screws to 39Nm.

Repeat for other side of staircase, and then repeat the entire procedure for the other staircase.

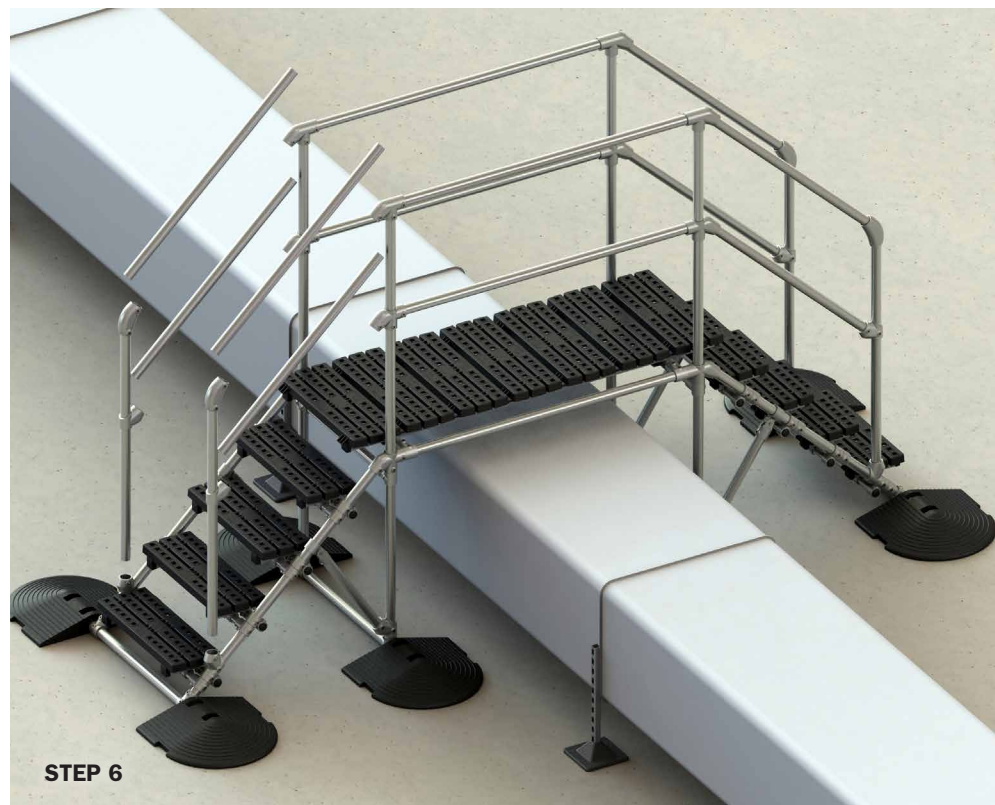

STEP 7 – Fitting toe board

Locate toe board (Part E) inboard of bridge platform and pick the TBFP1 fixing packs and TB3-7 toe-board fixing clamps.

Insert the M12 bolts into the extruded channel, and locate 1 bolt either side of each upright as shown in the illustration.

Locate the TB3 clip onto the bolts, fits the nuts and washers.

Level the toe board and tighten the fixings to 25Nm.



Assembling the Step Over

STEP 8 - Levelling and finalising of treads

With the platform now fully assembled, check the tread rise (distance in height between treads), going (where the tread sits in plan), and angle.

Starting at the bottom tread, measure the rise between the treads ensuring that there is no more than 5% difference between any two tread heights*.

Looking from above, there should be a minimum of 10mm overlap on the treads*.

Starting at the top tread, and using a spirit level, ensure that all treads are level left/right and forwards/backwards. If an adjustment needs to be made in the fore/aft level simply slacken the grub screws on the 45-76 and 10-76 on both sides, adjust tread to correct, level angle and re-tighten.

If adjustment needs to be made to accommodate the 10mm overlap between treads, simply undo the 13mm nuts holding the tread extrusion to the 199-6 fitting and adjust, ensuring that they are re-tightened on completion.

(* = The Stair rail and tread assemblies are pre-assembled at Kee Safety so no major adjustments should be required)



STEP 9 - Check and recheck all grub screws and finalise assembly

Once all treads are level, the platform is fully assembled, and the toe board is present **ALL** grub screws are to be torqued to 39Nm

Starting at the lower left staircase, working from the lowest point, systematically tighten all grub screws with a calibrated torque wrench and indelibly mark the grub screws with a paint marker once at torque.

This performs two functions, it lets the installer know once a grub screws has been tightened, but also on annual inspection allows the inspector to see if a grub screw has come loose and needs attention.

The same principle is applied to all other fixings, using 18Nm for all 13mm headed fixings, 25Nm on toe board M12 fixings and Tek Screws to be tightened until a compressing of the foam backed washer is observed.

It is IMPERATIVE that ALL grub screws and fixings are checked on the ENTIRE assembly and torqued up to the correct torque value and marked!!



Finished Step Over

6. Step Over assembled with 440-7 feet for membrane/asphalt/PVC roofs



Step Over assembled with 62-7/63-7 feet for concrete roofs



Step Over assembled with Top Fix baseplates for metal profile roofs



METAL PROFILE ROOF APPLICATION

Whilst we can supply Step Over platforms for membrane/asphalt/PVC and concrete from stock, owing to the vast variety of roofing profiles and fixing methods it is not possible to carry stocks of Step Over platforms specific to each roofing type and manufacturer.

A bespoke solution is available following a site survey to best advise on the product that is most suited to the requirement, contact Kee Safety for more information.

Kee Walk Mini Step Over

MINI STEP MODULE KITS

Low maintenance, **KEE WALK** Mini Step Over modules are made from Galvanised steel, Aluminium extrusion and reinforced Nylon treads and are tested and compliant to EN 516 Class 1-C. Available as kits, the Step Overs are supplied flat packed, but are quick and easy to assemble.

- 2 Height clearances options, 200mm and 400mm
- 3 lengths available, 3, 4 and 5 tread options
- Two fixing options, free standing and fixed



MINI STEP 200MM CLEARANCE - FIXED

Designed to clear obstacles up to 200mm in height, this Mini Step Over provides safe access over smaller hazards

STMFX2003 - 473mm clearance. Weight 14.05kg
STMFX2004 - 713mm clearance. Weight 15.55kg
STMFX2005 - 963mm clearance. Weight 17.05kg



MINI STEP 400MM CLEARANCE - FIXED

Designed to clear obstacles up to 400mm in height, this Mini Step Over provides safe access over larger hazards

STMFX4003 - 473mm clearance. Weight 36.24kg
STMFX4004 - 713mm clearance. Weight 37.34kg
STMFX4005 - 963mm clearance. Weight 39.24kg



MINI STEP 200MM CLEARANCE - FREE STANDING

With recycled PVC weighted bases to eliminate the need to fix the unit to the roof, this unit is designed to clear obstacles up to 200mm in height.

STMFS2003 - 240mm clearance. Weight 65.63kg
STMFS2004 - 490mm clearance. Weight 67.13kg
STMFS2005 - 740mm clearance. Weight 68.63kg



MINI STEP 200MM CLEARANCE - FREE STANDING

With recycled PVC weighted bases to eliminate the need to fix the unit to the roof, this unit is designed to clear obstacles up to 400mm in height.

STMFS2003 - 433mm clearance. Weight 83.93kg
STMFS2004 - 673mm clearance. Weight 85.43kg

GENERAL

Two options are available, free standing, which the unit stands on two 26kg base weights, or fixed, which can be attached to suitable securing surfaces.

KEE WALK Mini Step Over Fixed systems require physical fixing to the buildings structure.

KEE WALK Mini Step Over free standing systems are safe for wind speeds in excess of 86mph.

TESTING

All modules meet the requirements of EN 516 : 2006. Modules STMFS200* and STMFX200* also meet the requirements of EN 14122:3 - 2016.

INSTALLATION

Installation should be carried out by at least 2 competent persons. Step Over units can be heavy and care should be taken at all times.

You will need the following in order to install the Mini Step Over.

Tool list:

- 1No 13mm socket
- 1No 13mm spanner
- ¼" Hex key socket
- Torque wrench 10- 60 Nm approx
- Small magnetic level

DANGER TO LIFE!



Establish that the is installed correctly!! Failure to do so could result in death or serious injury.

Recycled PVC base weights weight in excess of 26KG each! Take care when handling.

Assembling and fixing the Mini Step Over - Fixed Version

STMFx400* MODULES



a) Unpack and check contents. The package should contain 1no. platform, 4no. long legs, 4no. short legs, 2no. step platforms, and M8 fixings. Add 4no. legs to step tread - 2no. short at the front and 2no. long at the back. Tighten grub screws.



b) Peel back rubber end cap and slide 2no. M8 bolts onto the end of the aluminium extrusion. Replace rubber end cap. Pass M8 bolts through 62-6 fitting and secure using M8 fixings and a 13mm spanner. Using a torque wrench tighten to 15N/m. Repeat process for 3 other long legs.



c) Turn unit over and place over obstacle. Either fix to surface or sturdy obstacle using appropriate fixing method. Ensure all fixings are tight with fittings torqued to 29N/m and M8 nuts are tightened to 15N/m.

STMFx200* MODULES

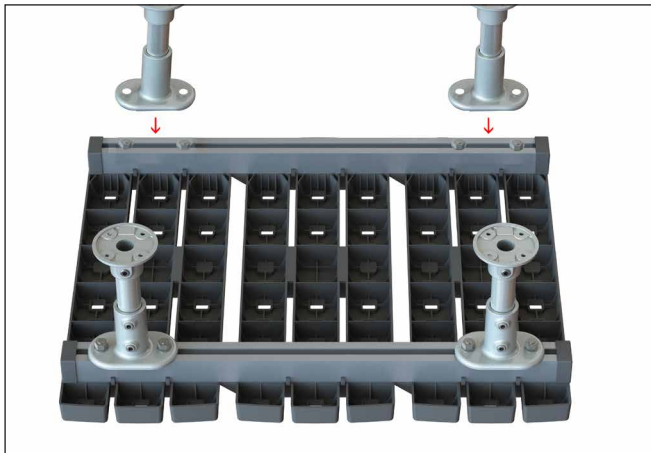

a) Unpack and check contents. The package should contain 1no. platform, 4no. legs and M8 fixings.

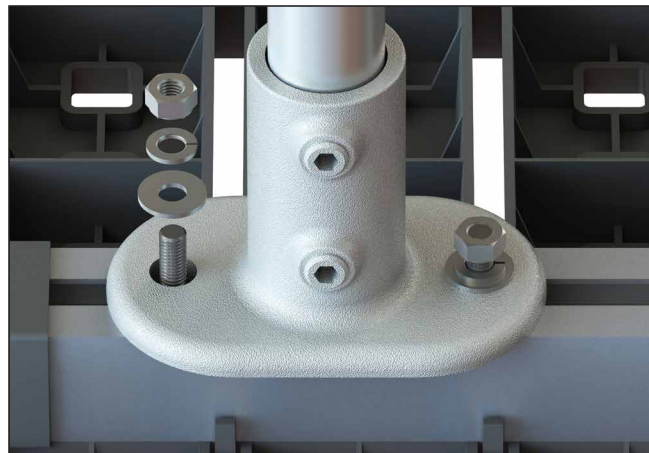

b) Peel back rubber end cap and slide 2no. M8 bolts onto the end of the aluminium extrusion. Replace rubber end cap. Pass M8 bolts through 62-6 fitting and secure using M8 fixings and a 13mm spanner. Using a torque wrench tighten to 15N/m. Repeat process for 3 other legs.

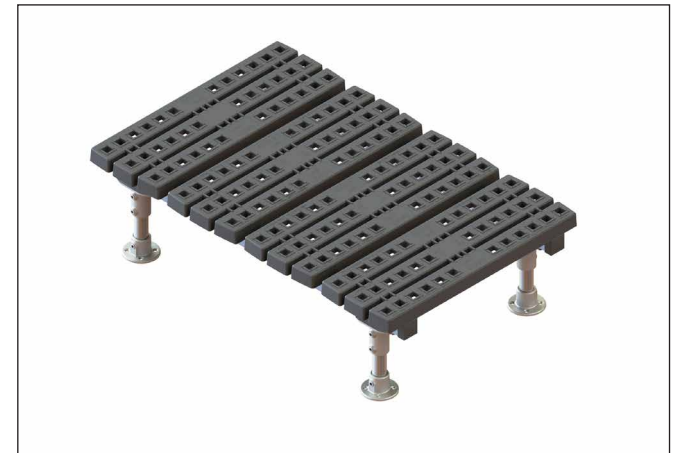

c) Turn unit over and place over obstacle. Either fix to surface or sturdy obstacle using appropriate fixing method. Ensure all fixings are tight with fittings torqued to 29N/m and M8 nuts are tightened to 15N/m.

STMFS400* MODULES



a) Unpack and check contents. The package should contain 1no. platform, 4no. legs, 2no. weighted bases and M8 fixings. Position weights either side of obstacle. Position legs so that the 62-6 oblong fittings are at the top and 61-6 sit on the floor. Slide fitting to tubes with vertical legs on the inside of the horizontal tubes as per diagram above. Tighten the grub screws.



b) Peel back rubber end cap and slide 2no. M8 bolts onto the end of the aluminium extrusion. Replace rubber end cap. Pass M8 bolts through 62-6 fitting and secure using M8 fixings and a 13mm spanner. Using a torque wrench tighten to 15N/m. Repeat process for 3 other legs.



c) Ensure all fixings are tight with fittings torqued to 29N/m and M8 nuts tightened to 15N/m.

STMFS200* MODULES

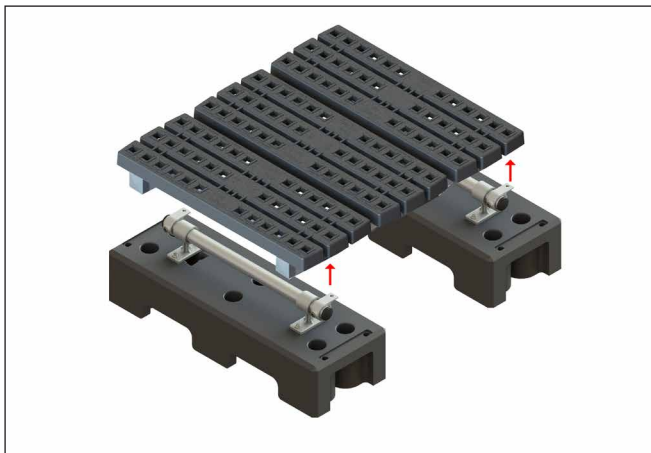

a) Unpack and check contents. The package should contain 1no. platform, 2no. weighted bases and M8 fixings. Place weighted bases in position either side of obstacle. Lower platform into position ensuring 199-6 fitting lines up with the aluminium extrusion as per diagram.

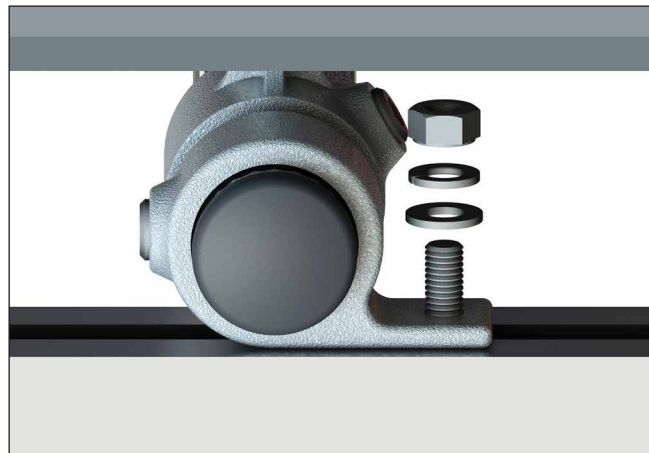

b) Peel back rubber end cap and slide 2no. M8 bolts onto the end of the aluminium extrusion. Pass M8 bolts through 199-6 fitting and secure using M8 fixings and a 13mm spanner. Using a torque wrench tighten to 15N/m. Repeat process for 3 other legs.

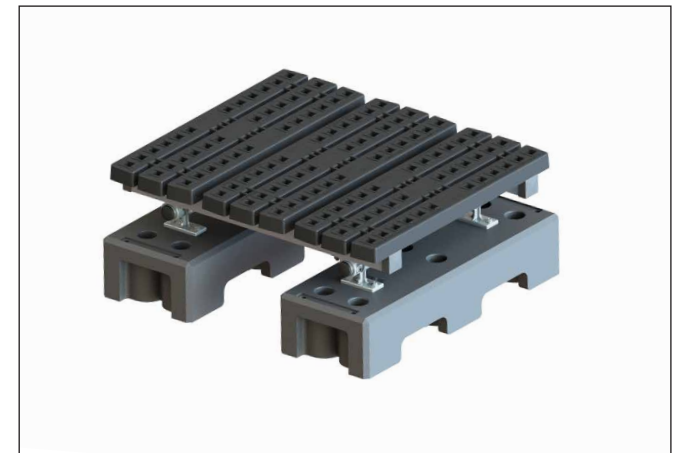

c) Ensure all fixings are tight with fittings torqued to 29N/m and M8 nuts tightened to 15N/m.

7. KEE WALK STEP OVER SYSTEM RECERTIFICATION

- Periodic inspections by a competent person are recommended by the manufacturer. In UK/Europe these are required under Regulation 5 of the Workplace (Health, Safety & Welfare) Regulations, the Work at Height Regulations and BS EN 365. The frequency will depend upon the environment, location and usage but should be at least every 12 months.
- Walk and visually inspect the complete installed system in relation to the client's general needs. Establish if any modifications and/or additional products are required to reflect any refurbishment requirements or additional plant & equipment which have been installed and require access.
- Check installation configuration is complete as per the original installation drawing/plan.
- Ensure the system has not been modified or tampered with by un-authorized persons.
- Check all base feet are in contact with the roof.
- Check all counter weights (where present on original drawing) are in place as per the original drawing. This is essential for longevity of the roof.
- Check all grub screws are in place and correctly torqued.
- Check the general height and level of the system including the leg centres and platform overall configuration.
(This only tends to be an issue if the system has been tampered with between inspections).
- Any galvanised components showing signs of corrosion should be wire brushed thoroughly and galvanised spray/paint applied as appropriate. If rusted significantly, take digital photographs and include these in the inspection report.
- Where toe boards are fitted check the brackets that support the toe board are in place and sufficiently torqued.
- Where applicable check fixings to walls/structures including cat ladder clamps are in place and sufficiently torqued.



KEE WALK® Step Over

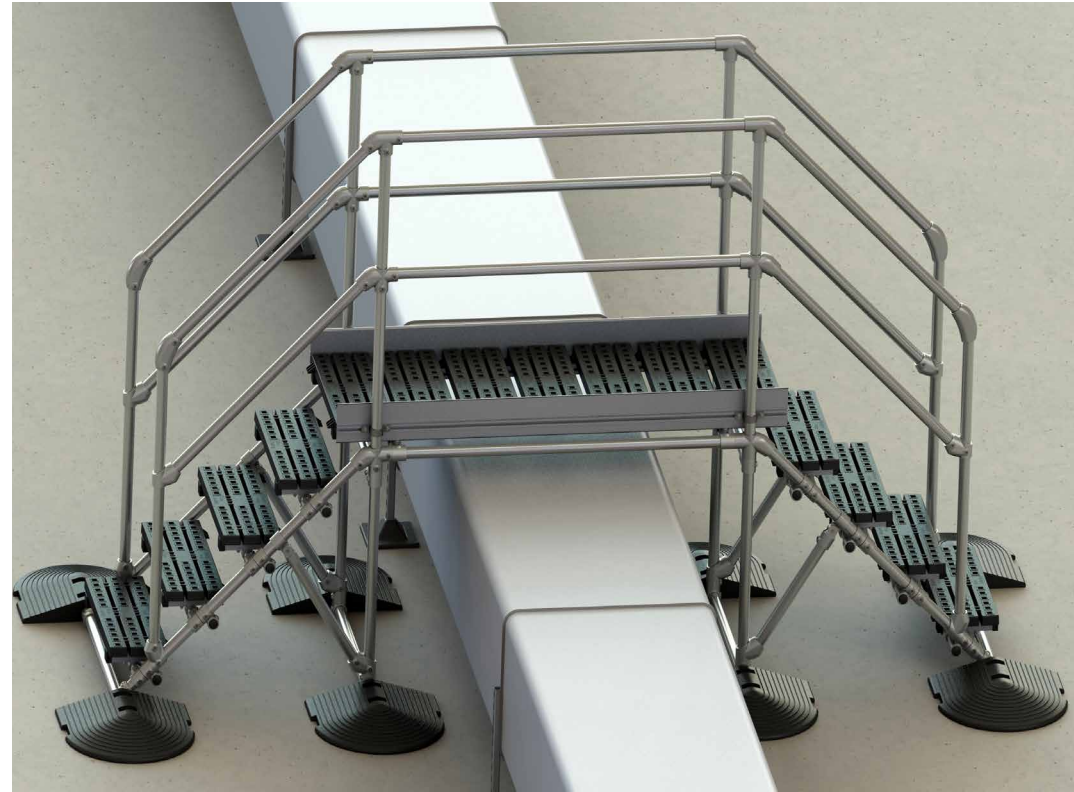

Kee Safety Ltd.
Cradley Business Park
Overend Road
Cradley Heath
West Midlands
B64 7DW

Tel: +44 (0) 1384 632188
Fax: +44 (0) 1384 632192

Email: sales@keesafety.com
www.keesafety.com

KEE WALK is a registered trademark of Kee Safety Ltd. Whilst every effort has been made to ensure the accuracy of the information contained within this brochure Kee Safety Ltd cannot be held responsible for any errors or omissions. Kee Safety Ltd reserves the right to alter or withdraw products without prior notice. Kee Safety Ltd accepts no responsibility for any loss or damage arising from improper use of their products. ©2016 Kee Safety Ltd. All Rights Reserved.